

view A

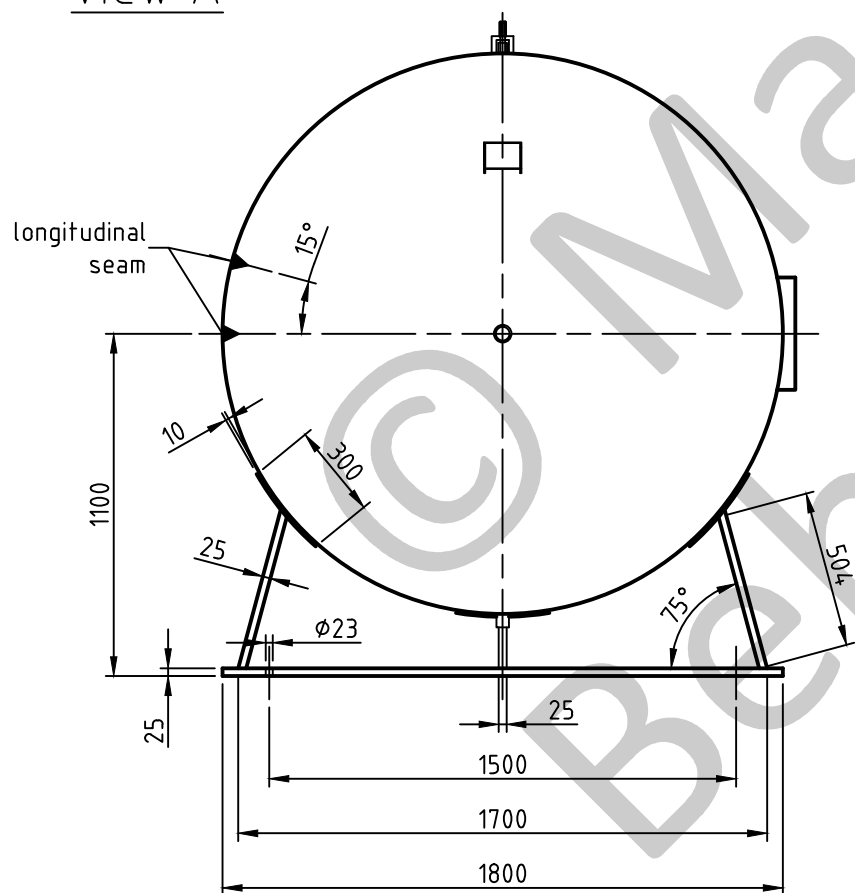

socket welding  
drain and plug socket  
inside flush

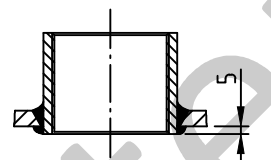

OAB 51 - manhole lock 320/420  
tested components

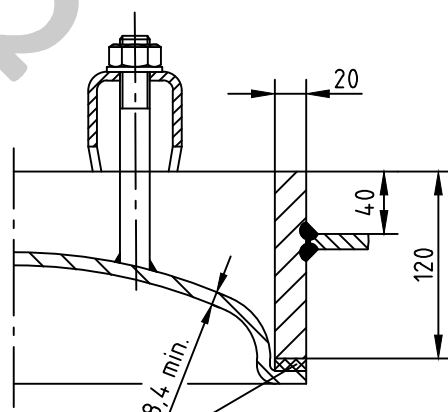

carrier eye

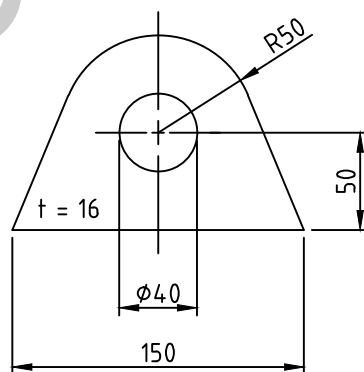

**SEAMS (unless otherwise indicated on drawing):**

longitudinal seam	socket-/flangeweldings	circumferential seams
		beadseams only up to 8mm wall thickness of bottoms cyl. brim > 3,5 x wall thickness of bottoms

pressure variation :
pressure swing 0-16 bar max. operations 1.000
infinite operation of pressure swing within 20% of 16 bar
operational characteristics / calculation characteristics :
volume V (litre) : 10000
max. working pressure PS (bar) : 16
test pressure PT (bar) : 22,88
min. working temp. TS (°C) : -10
max. working temp. TS (°C) : 50
fluid : compressed air/nitrogen (fluid group 2)
location : inside and outside building possible

coating :
inside : raw
outside : primed (if customer wishes lacquered)

manufacturing and testing
acc. to PED 2014 / 68 / EU - AD 2000

conformity benchmark :	
fluid group : 2	categorie : IV
diagram : 2	module : H1

scale :	1:25
our no. :	-
order no. :	-
used for :	M+B Standardvessel
weight :	ca.2520 kg
sheet :	1
of sheet :	1
date of plot :	07.07.2015
file :	ENG-010886

**Maschinen- und Behälterbau GmbH**

date	name
compl. 07.07.2015	CW
appr. 07.07.2015	Nota 2

follow protection mark acc. to DIN 34

Betzdorfer Str. 170  
57567 Daaden  
Tel. 02743/9330-12  
Fax 02743/3685  
Internet: www.mabe.de  
E-Mail: cad@mabe.de

description :	
pressure vessel horizontal 10000 l 16 bar	
drawing no. :	revision : A
MB 020102-2.10008G/E	
drawing no. of design inspection :	date of revision : 07.07.2015
MB 020102-2	revision only on CAD