

view A

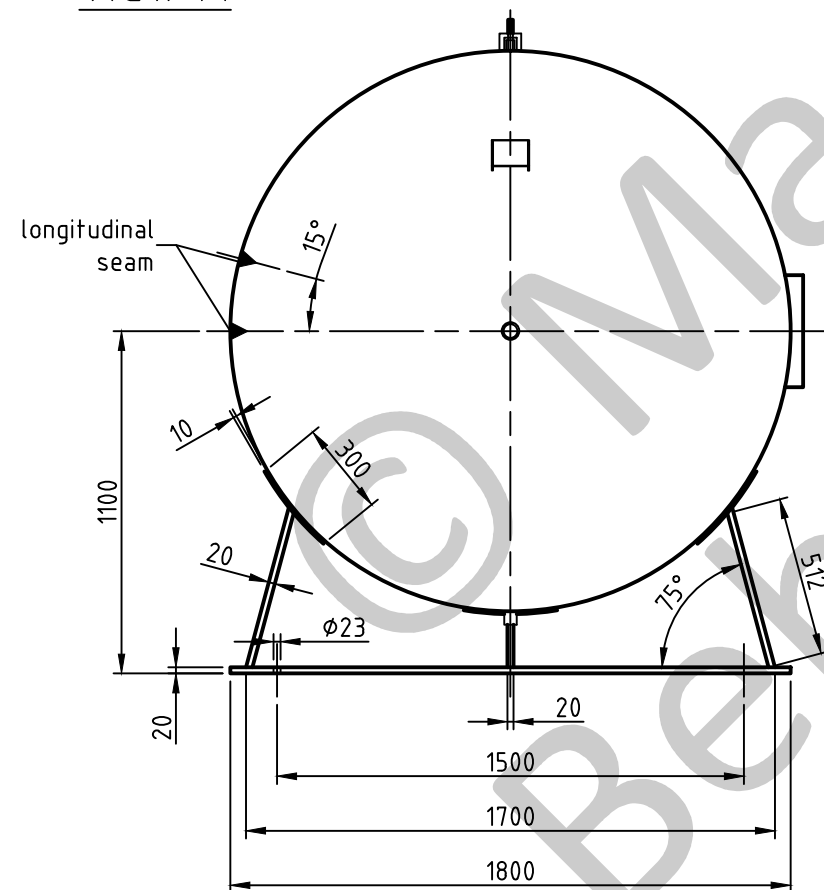

socket welding  
drain and plug socket  
inside flush

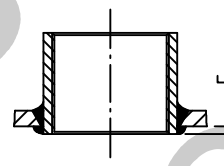

OAB 51 - manhole lock 320/420  
tested components

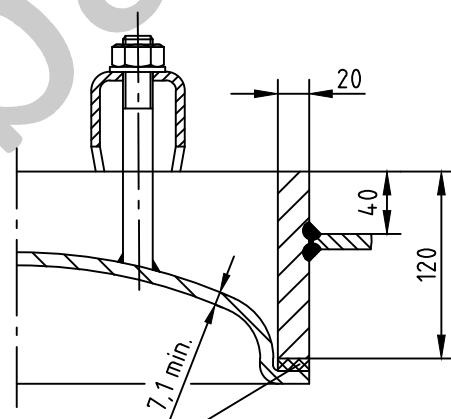

carrier eye

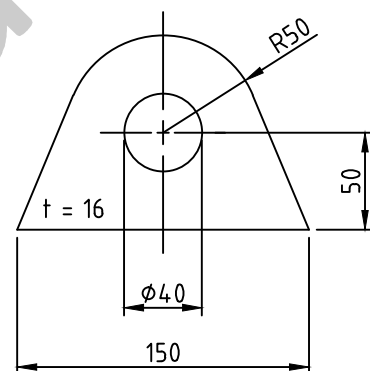

1a rubber gasket up to 70°C

**SEAMS (unless otherwise indicated on drawing):**

longitudinal seam	socket-/flangeweldings	circumferential seams
		beadseams only up to 8mm wall thickness of bottoms cyl. brim > 3,5 x wall thickness of bottoms

pressure variation :

pressure swing 0-11 bar max. operations 1.000

infinite operation of pressure swing within 20% of 11 bar

operational characteristics / calculation characteristics :

volume V (litre)	: 10000
max. working pressure PS (bar)	: 11
test pressure PT (bar)	: 15,73
min. working temp. TS (°C)	: -10
max. working temp. TS (°C)	: 50
fluid	: compressed air/nitrogen (fluid group 2)
location	: inside and outside building possible

coating :

inside : raw  
outside : primed (if customer wishes lacquered)

manufacturing and testing

acc. to PED 2014 / 68 / EU - AD 2000

conformity benchmark :

fluid group : 2	categorie : IV
diagram : 2	module : H1

scale :	1:25
our no. :	-
order no. :	-
used for :	M+B Standardvessel
weight :	ca.1830 kg
sheet :	1
of sheet :	1
date of plot :	24.06.2015
file :	ENG-010815

<b>Maschinen- und Behälterbau GmbH</b>	
date	name
compl. 24.06.2015	CW
appr. 24.06.2015	Nota 2
follow protection mark acc. to DIN 34	
Betzdorfer Str. 170 57567 Daaden Tel. 02743/9330-12 Fax 02743/3685 Internet: www.mabe.de E-Mail: cad@mabe.de	

description :

pressure vessel horizontal  
10000 l 11 bar

drawing no. :  
MB 020102-1.10008G/E

drawing no. of design inspection :

MB 020102-1

revision :

A

date of revision :  
24.06.2015

revision only  
on CAD