

OAB 51 - manhole lock 320/420
tested components

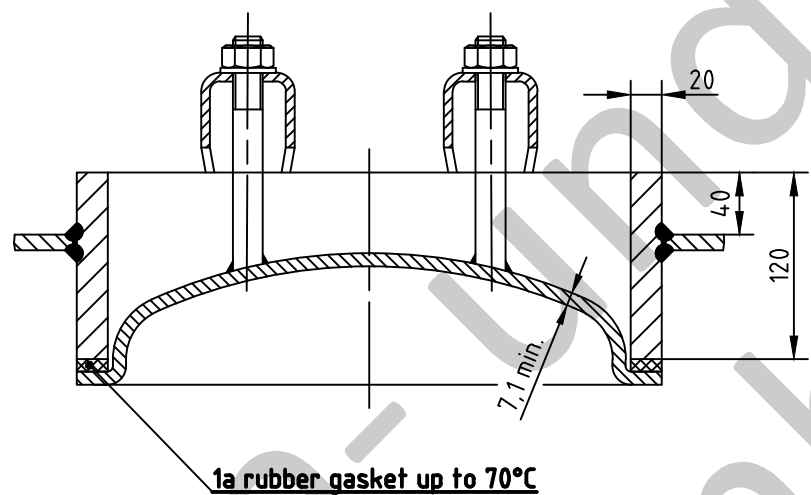

Detail X

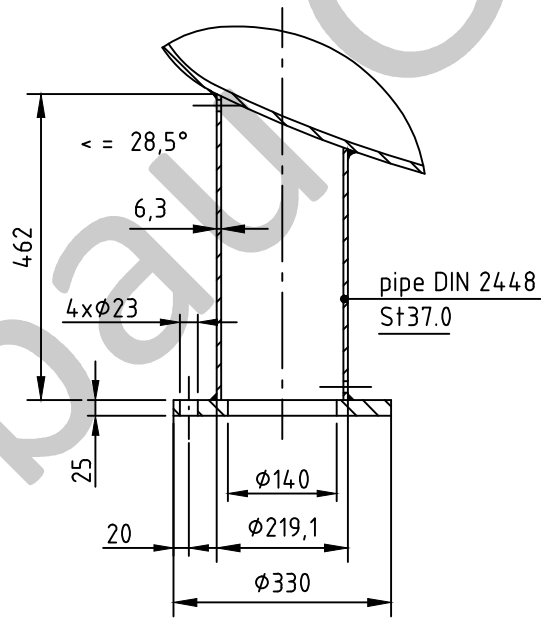

SEAMS (unless otherwise indicated on drawing):		
longitudinal seam	socket-/flangeweldings	circumferential seams
		beadseams only up to 8mm wall thickness of bottoms cyl. brim > 3,5 x wall thickness of bottoms
pressure variation :		
pressure swing 0-11 bar max. operations 1.000		
infinite operation of pressure swing within 20% of 11 bar		
operational characteristics / calculation characteristics :		
volume V (litre)	:	10000
max. working pressure PS (bar)	:	11
test pressure PT (bar)	:	15,73
min. working temp. TS (°C)	:	-10
max. working temp. TS (°C)	:	50
fluid	:	compressed air / nitrogen (fluid group 2)
location	:	inside and outside building possible
coating :		
inside : raw		
outside : primed (if customer wishes lacquered)		
manufacturing and testing		
acc. to PED 2014 / 68 / EU - AD 2000		
conformity benchmark :		
fluid group : 2	category : IV	
diagram : 2	module : H1	

scale :	1:30
our no. :	-
order no. :	-
used for :	M+B Standardvessel
weight :	ca.1830 kg
sheet :	1
of sheet :	1
date of plot :	16.06.2015
file :	ENG-010717

Maschinen- und Behälterbau GmbH

date name

compl. 16.06.2015 CW

appr. 16.06.2015 *Nota 2*

follow protection mark acc. to DIN 34

Betzdorfer Str. 170
57567 Daaden
Tel. 02743/9330-12
Fax 02743/3685
Internet: www.mabe.de
E-Mail: cad@mabe.de

description :		pressure vessel upright 10000 l 11 bar	revision : A
drawing no. :			
drawing no. of design inspection :		MB 020103-1.10008G/E	date of revision : 16.06.2015
drawing no. :		MB 020103-1	revision only on CAD