

OAB 51 - handhole lock 100/150  
tested components

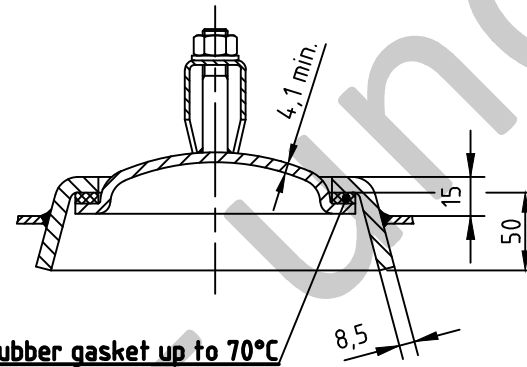

socket welding  
drain and plug socket  
inside flush

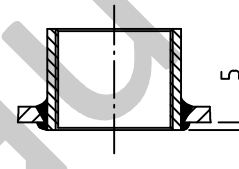

carrier eye

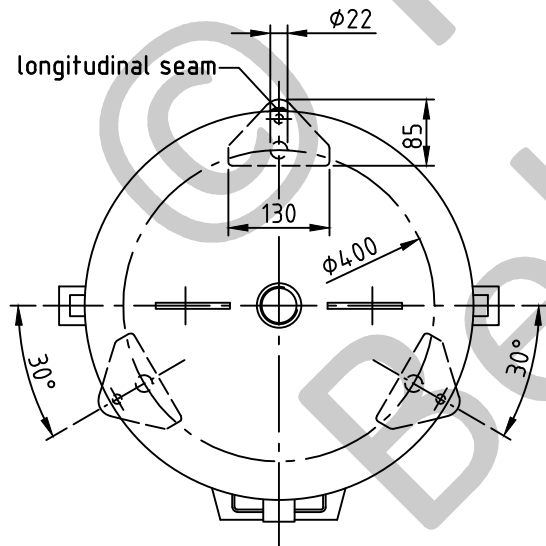
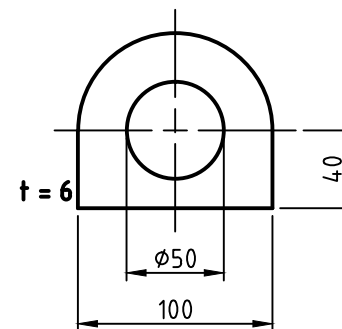

**SEAMS (unless otherwise indicated on drawing):**

longitudinal seam	socket-/flangeweldings	circumferential seams
		beadseams only up to 8mm wall thickness of bottoms cyl. brim > 3,5 x wall thickness of bottoms

pressure variation :
pressure swing 0-11 bar max. operations 1.000
infinite operation of pressure swing within 20% of 11 bar
operational characteristics / calculation characteristics :
volume V (litre) : 250
max. working pressure PS (bar) : 11
test pressure PT (bar) : 15,73
min. working temp. TS (°C) : -20
max. working temp TS (°C) : 50
fluid : compressed air / nitrogen (fluid group 2)
location : inside and outside building possible

coating :	
inside : raw	or: inside : hot dip galvanized
outside : primed (if customer wishes lacquered)	outside : hot dip galvanized

manufacturing and testing
acc. to PED 2014 / 68 / EU - AD 2000

conformity benchmark :	
fluid group : 2	categorie : III
diagram : 2	module : H1

scale :	1:10
our no. :	-
order no. :	-
used for :	M+B Standardvessel
weight :	ca.100 kg
sheet :	1
of sheet :	1
date of plot :	10.06.2015
file :	ENG-010669

**Maschinen- und Behälterbau GmbH**

date	name
compl. 10.06.2015	CW
appr. 10.06.2015	<i>Nota 2</i>

follow protection mark acc. to DIN 34

Betzdorfer Str. 170  
57567 Daaden  
Tel. 02743/9330-12  
Fax 02743/3685  
Internet: www.mabe.de  
E-Mail: cad@mabe.de

description :	
pressure vessel upright 250 l 11 bar	
drawing no. :	revision : A
MB 030603-1.250/E	
drawing no. of design inspection :	date of revision : 10.06.2015
MB 030603-1	revision only on CAD