

OAB 51 - handhole lock 100/150
tested components

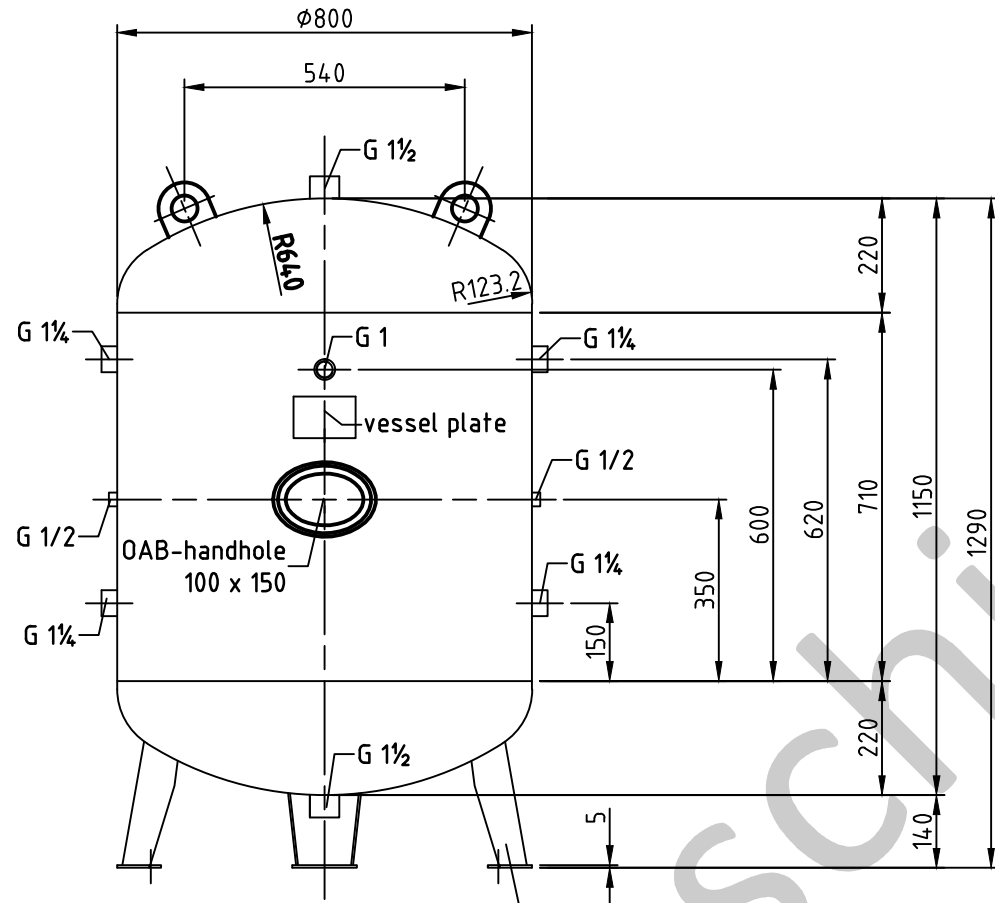

socket welding
drain and plug socket
inside flush

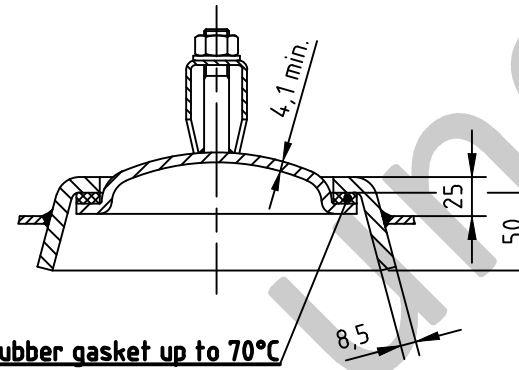
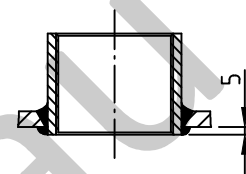

carrier eye

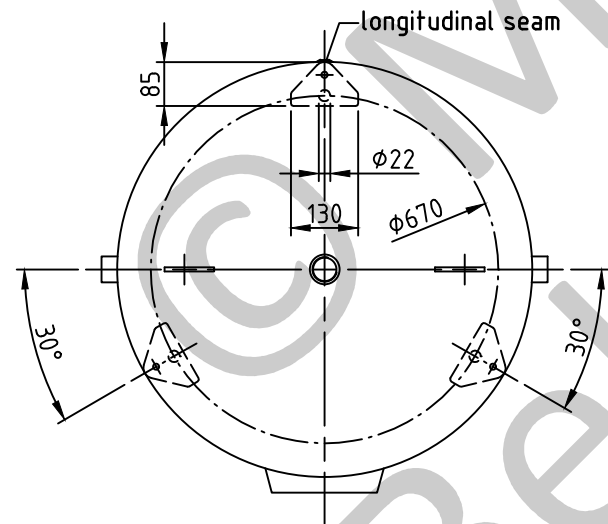
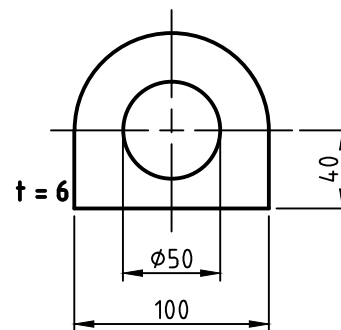

SEAMS (unless otherwise indicated on drawing):

longitudinal seam	socket-/flangeweldings	circumferential seams
		beadseams only up to 8mm wall thickness of bottoms cyl. brim > 3,5 x wall thickness of bottoms

pressure variation :

pressure swing 0-11 bar max. operations 1.000

infinite operation of pressure swing within 20% of 11 bar

operational characteristics / calculation characteristics :

volume V (litre)	: 500
max. working pressure PS (bar)	: 11
test pressure PT (bar)	: 15,73
min. working temp. TS (°C)	: -20
max. working temp. TS (°C)	: 50
fluid	: compressed air / nitrogen (fluid group 2)
location	: inside and outside building possible

coating :

inside : raw
outside : primed (if customer wishes lacquered) or: inside : hot dip galvanized
outside : hot dip galvanized

manufacturing and testing

acc. to PED 2014 / 68 / EU - AD 2000

conformity benchmark :

fluid group : 2
diagram : 2
categorie : IV
module : H1

scale :	1:15
our no. :	-
order no. :	-
used for :	M+B Standardvessel
weight :	ca.180 kg
sheet :	1
of sheet :	1
date of plot :	10.06.2015
file :	ENG-010677

Maschinen- und Behälterbau GmbH

	date	name
compl.	10.06.2015	CW
appr.	10.06.2015	Nota 2

follow protection mark acc. to DIN 34

Betzdorfer Str. 170
57567 Daaden
Tel. 02743/9330-12
Fax 02743/3685
Internet: www.mabe.de
E-Mail: cad@mabe.de

description :	
pressure vessel upright 500 l 11 bar	
drawing no. :	revision : A
MB 030605-1.500/E	
drawing no. of design inspection :	date of revision : 10.06.2015
MB 020103-1	revision only on CAD