

OAB 51 - handhole lock 100/150
tested components

socket welding
drain and plug socket
inside flush

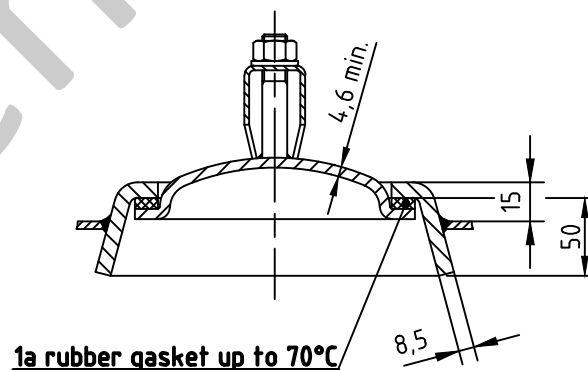
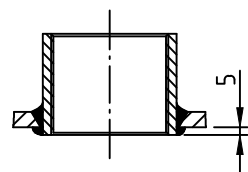

1a rubber gasket up to 70°C

SEAMS (unless otherwise indicated on drawing):

longitudinal seam	socket-/flangeweldings	circumferential seams
		beadseams only up to 8mm wall thickness of bottoms cyl. brim > 3,5 x wall thickness of bottoms

pressure variation :
pressure swing 0-16 bar max. operations 1.000
infinite operation of pressure swing within 20% of 16 bar
operational characteristics / calculation characteristics :
volume V (litre) : 250
max. working pressure PS (bar) : 16
test pressure PT (bar) : 22,88
min. working temp. TS (°C) : -20
max. working temp. TS (°C) : 50
fluid : compressed air (fluid group 2)
location : inside and outside building possible

coating :		
inside : raw	or:	inside : hot dip galvanized
outside : primed (if customer wishes lacquered)		outside : hot dip galvanized

manufacturing and testing
acc. to PED 2014 / 68 / EU - AD 2000

conformity benchmark :	
fluid group : 2	categorie : IV
diagram : 2	module : H1

scale :	1:12.5
our no. :	-
order no. :	-
used for :	M+B Standardvessel
weight :	ca.120 kg
sheet :	1
of sheet :	1
date of plot :	24.06.2015
file :	ENG-010823

Maschinen- und Behälterbau GmbH

	date	name
compl.	24.06.2015	CW
appr.	24.06.2015	Nota 2

follow protection mark acc. to DIN 34

Betzdorfer Str. 170
57567 Daaden
Tel. 02743/9330-12
Fax 02743/3685
Internet: www.mabe.de
E-Mail: cad@mabe.de

description :	pressure vessel horizontal 250 l 16 bar
drawing no. :	MB 030602-2.250/E
revision :	A
date of revision :	24.06.2015
drawing no. of design inspection :	MB 030602-2
revision only on CAD	