

socket welding
drain and plug socket
inside flush

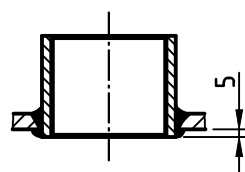

OAB 51 - handhole lock 100/150
tested components

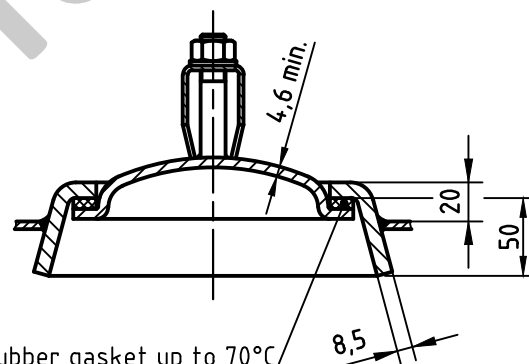

SEAMS (unless otherwise indicated on drawing):

| longitudinal seam | socket-/flangeweldings | circumferential seams |
|-------------------|------------------------|---|
| | | beadseams only up to 8mm wall thickness of bottoms cyl. brim > 3,5 x wall thickness of bottoms |

| | |
|--|---|
| pressure variation : | |
| pressure swing 0-16 bar max. operations 1.000 | |
| infinite operation of pressure swing within 20% of 16 bar | |
| operational characteristics / calculation characteristics : | |
| volume V (litre) | : 500 |
| max. working pressure PS (bar) | : 16 |
| test pressure PT (bar) | : 22,88 |
| min. working temp. TS (°C) | : -20 |
| max. working temp. TS (°C) | : 50 |
| fluid | : compressed air/nitrogen (fluid group 2) |
| location | : inside and outside building possible |

coating :
 inside : raw
 outside : primed (if customer wishes lacquered) **or:** inside : hot dip galvanized
 outside : hot dip galvanized

manufacturing and testing
 acc. to PED 2014 / 68 / EU - AD 2000

conformity benchmark :
 fluid group : 2
 diagram : 2
 categorie : IV
 module : H1

| | |
|----------------|--------------------|
| scale : | 1:12.5 |
| our no. : | - |
| order no. : | - |
| used for : | M+B Standardvessel |
| weight : | ca.150 kg |
| sheet : | 1 |
| of sheet : | 1 |
| date of plot : | 24.06.2015 |
| file : | ENG-010825 |

Maschinen- und Behälterbau GmbH

| | date | name |
|--------|------------|--------|
| compl. | 24.06.2015 | CW |
| appr. | 24.06.2015 | Nota 2 |

follow protection mark acc. to DIN 34

Betzdorfer Str. 170
 57567 Daaden
 Tel. 02743/9330-12
 Fax 02743/3685
 Internet: www.mabe.de
 E-Mail: cad@mabe.de

| | |
|--|-------------------------------|
| description : | |
| pressure vessel horizontal 500 l 16 bar | |
| drawing no. : | revision : A |
| MB 030602-2.500/E | |
| drawing no. of design inspection : | date of revision : 24.06.2015 |
| MB 030602-2 | revision only on CAD |