

G 2x=G 2 galva.-socket

socket welding
drain and plug socket
inside flush

OAB 51 - manhole lock 320/420
tested components

view A

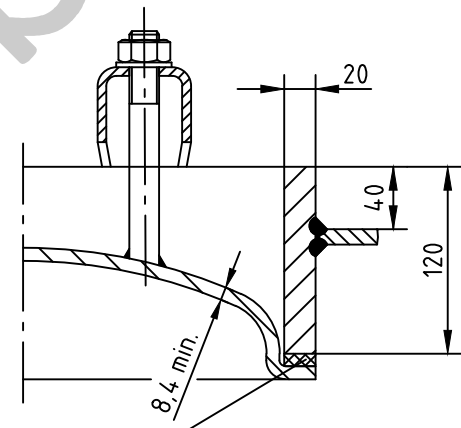
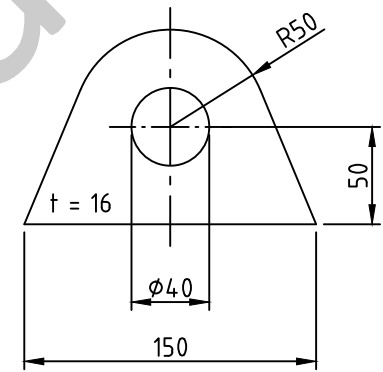
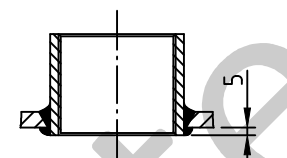
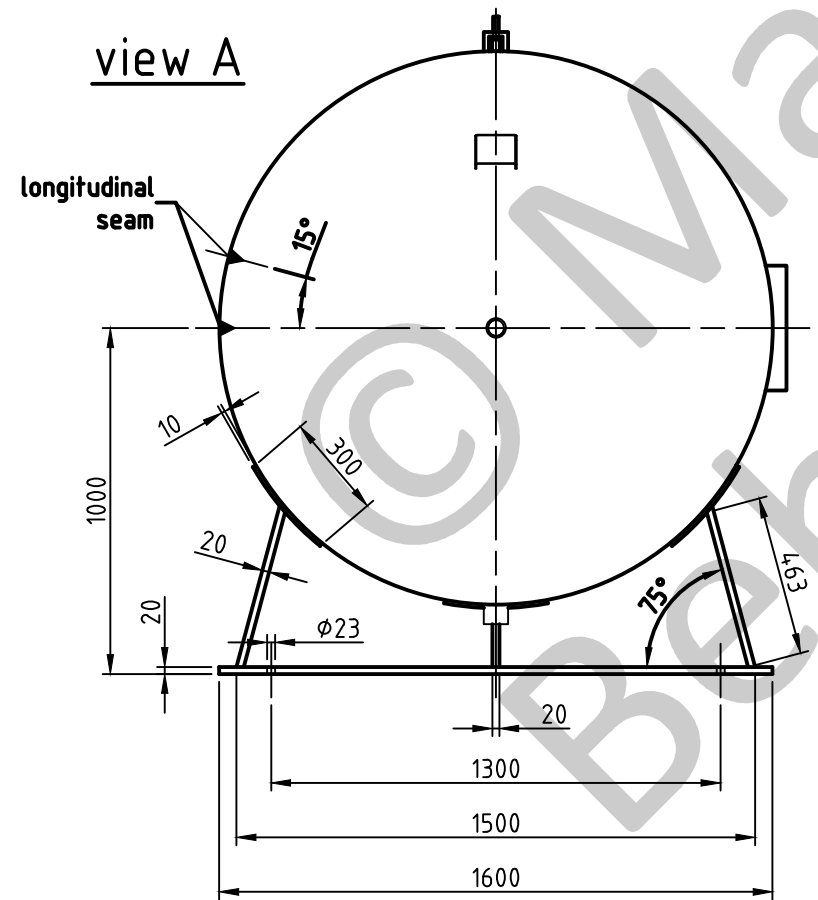

1a rubber gasket up to 70°C

SEAMS (unless otherwise indicated on drawing):

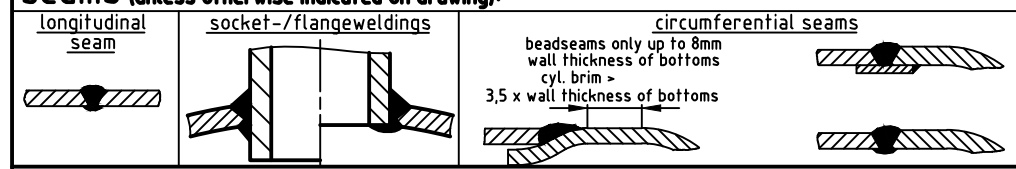

pressure variation :	
pressure swing 0-16 bar max. operations 1.000	
infinite operation of pressure swing within 20% of 16 bar	
operational characteristics / calculation characteristics :	
volume V (litre)	: 9000
max. working pressure PS (bar)	: 16
test pressure PT (bar)	: 22,88
min. working temp. TS (°C)	: -10
max. working temp. TS (°C)	: 50
fluid	: compressed air/nitrogen (fluid group 2)
location	: inside and outside building possible

coating :
inside : hot dip galvanized
outside : hot dip galvanized

manufacturing and testing
acc. to PED 2014 / 68 / EU - AD 2000

conformity benchmark :
fluid group : 2
diagram : 2
categorie : IV
module : H1

scale :	1:22.5
our no. :	-
order no. :	-
used for :	M+B Standardvessel
weight :	ca.2320 kg
sheet :	1
of sheet :	1
date of plot :	07.07.2015
file :	ENG-010883

Maschinen- und Behälterbau GmbH

date	name
compl. 07.07.2015	CW
appr. 07.07.2015	Nota 2

follow protection mark acc. to DIN 34

Betzdorfer Str. 170
57567 Daaden
Tel. 02743/9330-12
Fax 02743/3685
Internet: www.mabe.de
E-Mail: cad@mabe.de

description :	
pressure vessel horizontal 9000 l 16 bar	
drawing no. :	revision : A
MB 020102-2.9000V/E	
drawing no. of design inspection :	date of revision : 07.07.2015
MB 020102-2	revision only on CAD